



**GE Arresters**

# **TRANQUELL® Surge Arresters**

*Product Selection & Application Guide*





# Table of Contents

---

<i>Introduction .....</i>	<i>4</i>
<i>Arrester Rating Selection Application Guide ..</i>	<i>5</i>
<i>Arrester Service Conditions and Other Considerations .....</i>	<i>9</i>
<i>Insulation Coordination .....</i>	<i>11</i>
<i>Arrester Modeling .....</i>	<i>13</i>
<i>Extra High Voltage Arrester Specifications...</i>	<i>15</i>
<i>Arrester Detailed Specifications:</i>	
<i>Polymer Station Arrester .....</i>	<i>16</i>
<i>Polymer Intermediate Arrester .....</i>	<i>18</i>
<i>Polymer Heavy Arrester .....</i>	<i>19</i>
<i>Heavy Duty Distribution Arrester.....</i>	<i>20</i>
<i>Riser Pole Arrester .....</i>	<i>21</i>
<i>Polymer Normal Duty Distribution Arrester..</i>	<i>22</i>
<i>Special Applications of TRANQUELL Metal Oxide Technology .....</i>	<i>23</i>
<i>References .....</i>	<i>24</i>

## *GE Surge Protection...*

The performance and reliability of today's electric power system can be enhanced with the unique characteristics of GE TRANQUELL® arrester products. Since introducing the world's first metal oxide arrester in 1976, offering new concepts in surge arrester design and application, GE has developed and applied metal oxide technology for a variety of traditional and special applications. GE offers one of the most complete lines of surge arrester products in the world today; EHV arresters up to 612 kV rating as well as high energy varistors for series capacitor applications.

Starting with the state-of-the-art world class disk technology, all the way through the ISO 9001 approved design, assemble and test processes, GE offers extremely reliable arrester products.

Product and power systems engineers work closely to optimize product performance on the system. This tradition has made GE the world's leading supplier of metal oxide arresters and specialty varistors.

The GE arrester provides both excellent protective characteristics and temporary overvoltage capability. The gapless construction provides a design which is simple and reliable while remaining economical. TRANQUELL Polymer and porcelain arresters are designed to meet the most demanding service conditions.



Figure 1. TRANQUELL Porcelain Station Arrester



### General

GE TRANQUELL® arresters are designed and tested in accordance with ANSI/IEEE C62.11 and IEC 99-4[2,3]. The standard TRANQUELL arrester consists of a stack of metal oxide disks mounted in a sealed housing. Each disk is wedged in place offering protection against physical damage during shipment and installation. On the end faces of each disk, a conducting surface is applied to assure proper contact and uniform current distribution.

TRANQUELL arresters provide exceptional overvoltage protection of major power system equipment. Under normal system conditions, the arrester conducts less than one milliamper. When a surge reaches the arrester, the arrester conducts only the current necessary to limit the overvoltage. As a result, TRANQUELL arresters absorb minimum energy to protect equipment insulation.

### Metal Oxide Disks

Metal oxide valve elements are composed of a specially formulated compound of zinc oxide and small amounts of other selected metal oxides. These ingredients are mixed in powdered form, pressed to form a disk, and fired at high temperatures, resulting in a dense polycrystalline ceramic.

The basic molecular structure is a matrix of highly conductive zinc oxide grains surrounded by resistive intergranular layers of metal oxide elements. Under electrical stress, the intergranular layers conduct, resulting in a highly nonlinear characteristic. For example, a change of arrester current of 100,000 to 1 (0.1A to 10,000A) results in a voltage change of only 54 percent. Metal oxide elements in TRANQUELL arresters maintain stable characteristics. Accelerated life tests show that arrester losses will not increase during an arrester's service life when exposed to a continuous steady-state voltage. Stable metal oxide characteristics enable TRANQUELL arresters to maintain their low protective characteristics. As a result, equipment protection is never compromised.

Metal oxide valve elements in TRANQUELL arresters maintain a very stable characteristic. Accelerated aging tests show that the arrester power losses will not

increase during its service life when exposed to continuous operating voltage in any type of environment. Stable metal oxide disk characteristics enable TRANQUELL arresters to maintain their low protective characteristics. As a result, equipment protection is never compromised.

### Disk Collaring

The collaring system used on GE varistor disks, has a dual purpose:

- 1) To provide an insulating collar to prevent flashover at high currents.
- 2) To prevent the disk watts from increasing during aging from surface oxygen reduction.

The GE high dielectric insulating collar system is a nonporous, non-lead ceramic crystalline that completely seals the circumference of the disk preventing any oxygen depletion from the zinc oxide grains. This system insures the varistor disk will have a stable aging characteristic in any surrounding atmosphere; gas, liquid or solid. Many collar systems can provide the insulation withstand to prevent flashover at high currents but only a nonporous inorganic material can insure long term stable aging characteristics.

### Arrester Construction

#### Polymer Surge Arresters

GE Tranquell polymer surge arresters are constructed utilizing a rugged field-proven silicone alloy housing placed over a unique high-strength fiberglass woven assembly of stacked metal oxide elements. In order to prevent moisture ingress, the air space between the housing and fiberglass housing is filled with a hydrophobic dielectric grease. As additional protection, the cast metal end fittings of the arresters are tightly sealed around the polymer housing. This state-of-the-art assembly yields an arrester that is stronger and more rugged than any polymer arrester in the industry.

Along with unrivaled mechanical strength, GE Tranquell polymer arresters offer exceptional electrical characteristics such as low protective levels, high energy handling capability, and improved TOV capability. The electrical performance of the polymer

arresters is enhanced by its ability to easily transfer heat from the metal oxide elements to the outside environment. This design is far superior to the restricted air convection utilized in other porcelain designs.

#### Porcelain EHV Arrester

TRANQUELL EHV arresters incorporate a heat transfer system utilizing silicone-rubber material wedged between the metal oxide disk and internal porcelain wall. Heat generated in the valve element from steady state, temporary, or transient conditions is transferred through the silicone-rubber material to the porcelain housing and then dissipated to the outside environment.

Each galvanized end fitting is gasketed and cemented to the porcelain housing providing a complete moisture tight seal. This simple and rugged construction protects against internal arrester damage during shipment and installation.

### Arrester Testing

#### DURABILITY TESTS & QUALITY ASSURANCE

TRANQUELL arresters comply with the design tests outlined in ANSI/IEEE C62.11 and IEC 99-4. They exceed the requirements for the duty-cycle test, high-current short-duration test, and the low-current long-duration test (transmission line discharge test) with no loss in protective capability.

The ANSI/IEEE duty-cycle test and IEC operating duty test verify that the TRANQUELL arresters can dissipate lightning and switching surges while operating at rated voltage, and thermally recover at maximum continuous operating voltage (MCOV) of 60°C at an elevated temperature. In other words, the arrester can self-cool under applied voltage after absorbing transient energy.

Gapless construction and a special shed design provide excellent contamination performance exceeding ANSI/IEEE contamination test requirements. More demanding tests performed on TRANQUELL arresters also indicate they have an outstanding capability to withstand the effects of severe external contamination. Factory tests are performed on each metal oxide disk. Long-term stability tests are conducted on each



# GE Surge Arresters

and optimized. Every disk is subjected to an impulse current of 10kA 8/20 μs to measure its discharge voltage or nominal protective level. A disk strength test se-

ries, consisting of multiple transmission-line discharges, is performed to make certain that the disk has full energy capability.

## Application Guide for Selection of Arrester Rating

The objective of arrester application is to select the lowest rated surge arrester that will have a satisfactory service life on the power system while providing adequate protection of equipment insulation. An arrester

of the minimum practical rating is generally preferred because it provides the greatest margin of protection for the insulation. The use of a higher rating increases the capability of the arrester to survive on the

power system, but reduces the margin of protection it provides for a specific insulation level. Thus, arrester selection must strike a balance between arrester survival and equipment protection.

Table 1 lists arrester ratings that would normally be applied on systems of various line-to-line voltages. The rating of the arrester is defined as the rms voltage at which the arrester passes the duty-cycle test as defined by the referenced standard. To decide which rating is most appropriate for a

particular application, consideration must be given to the following system stresses to which the arrester will be exposed:

- Continuous system voltage
- Temporary overvoltages
- Switching surges (frequently a consideration in transmission systems of 345

kV and above, and for capacitor banks and cable applications)  
 ■ Lightning surges

The arrester selected must have sufficient capability to meet the anticipated service requirements in all categories.

Arrester Rating (kV)			Arrester Rating (kV)				
Nominal System L-L Voltage (kV)	Grounded Neutral Circuits	High Impedance Grounded, Ungrounded, or Temporarily Ungrounded	Nominal System L-L Voltage (kV)	Grounded Neutral Circuits	High Impedance Grounded, Ungrounded, or Temporarily Ungrounded		
2.4	2.7	3.0	69	54	--		
				60	--		
4.16	3.0	--	115	--	66		
	4.5	4.5		--	72		
4.8	4.5	5.1	138	90	--		
		--		5.1	96	--	
	6.0	6.0		108	108		
		--		6.0	--	120	
6.9	6.0	--	161	108	--		
		--		7.5	120	--	
	12.47	8.5		--	230	--	132
						--	144
13.2,13.8	9.0	--	345	120	--		
	10	--		132	--		
	--	12		144	144		
	--	15		--	168		
23, 24.94	10	--	400	172	--		
	12	--		180	--		
	--	15		192	--		
	--	18		--	228		
34.5	18	--	400	--	240		
	21	--		258	--		
	24	24		264	--		
	--	27		276	--		
46	27	--	400	288	288		
	30	--		294	294		
	--	36		300	300		
	--	39		312	312		
46	39	--	400	300	--		
	--	48		312	--		
				336	--		
				360	--		

NOTE: The arrester TOV capability must exceed the magnitude and duration of the expected temporary overvoltages considering the response time of primary and back-up system protection.



CONTINUOUS SYSTEM VOLTAGE

Arresters in service are continually exposed to system operating voltage. For each arrester rating, there is a recommended limit to the magnitude of voltage which may be continuously applied. This has been termed the Maximum Continuous Operating Voltage (MCOV) of the arrester. The MCOV of each TRANQUELL® arrester is contained in Table 2. These values meet or exceed those values contained in the referenced standard. The arrester rating must be selected such that the maximum continu-

ous power system voltage applied to the arrester is less than, or equal to, the arrester's continuous voltage capability. Attention must be given to both the circuit connection (single phase, wye or delta) and the arrester connection (line-to-ground, line-to-line). In most cases, the arrester is connected line-to-ground and therefore must withstand line-to-ground system operating voltage. If an arrester is to be connected line-to-line, phase-to-phase voltage must be considered. In addition, attention

should be given to an arrester application on the delta tertiary winding of a transformer where one corner of the delta is permanently grounded. In such circuits, the normal voltage continuously applied to the arrester will be the full phase-to-phase voltage even though the arresters are connected line-to-ground.

Table 2(a) & (b): TRANQUELL Polymer and Porcelain Arrester Characteristics

Table 2a Polymer Station Arrester Characteristics									
Rated Voltage kVrms	MCOV kVrms	0.5 μsec 10 kA Max IR-kVcrest	Switching Surge Maximum IR-kVcrest <sup>1</sup>	8/20 μs Maximum Discharge Voltage - kVcrest					
				1.5 kA	3 kA	5 kA	10 kA	20 kA	40 kA
3	2.55	8.4	6.0	6.4	6.7	7.1	7.6	8.4	9.6
6	5.10	16.7	11.9	12.8	13.5	14.1	15.2	16.8	19.1
9	7.65	25.0	17.8	19.2	20.2	21.1	22.7	25.1	28.3
10	8.40	27.8	19.8	21.4	22.5	23.5	25.3	28.0	31.8
12	10.2	33.3	23.7	25.6	26.9	28.1	30.3	33.5	38.1
15	12.7	41.7	29.7	32.0	33.7	35.2	37.9	42.0	47.6
18	15.3	50.1	35.6	38.4	40.4	42.3	45.5	50.0	57.2
21	17.0	56.3	40.1	43.2	45.5	47.6	51.2	56.7	64.4
24	19.5	63.9	45.5	49.1	51.6	54.0	58.1	64.3	73.0
27	22.0	72.9	51.9	56.0	58.9	61.6	66.3	73.4	83.3
30	24.4	80.4	57.2	61.7	64.9	67.9	73.1	80.9	91.9
36	29.0	95.9	68.3	73.6	77.4	81.0	87.2	96.5	109.6
39	31.5	104.2	74.2	80.0	84.1	88.0	94.7	104.8	119.0
45	36.5	120.9	86.1	92.8	97.6	102.1	109.9	121.7	138.1
48	39.0	128.7	91.6	98.8	103.9	108.7	117.0	129.5	147.1
54	42.0	144.4	102.8	110.9	116.6	122.0	131.3	145.3	165.0
60	48.0	163.5	116.4	125.5	132.0	138.0	148.6	164.5	186.8
66	53.0	179.9	128.0	138.1	145.2	151.8	163.5	181.0	205.5
72	57.0	191.8	136.6	147.3	154.9	162.0	174.4	193.1	219.2
90	70.0	241.8	172.1	185.6	195.2	204.2	219.8	243.3	276.3
96	76.0	257.4	183.2	197.6	207.8	217.4	234.0	259.0	294.1
108	84.0	288.9	205.6	221.8	233.2	244.0	262.6	290.7	330.1
120	98.0	326.9	241.3	251.0	263.9	276.1	297.2	329.0	373.6
132	106.0	362.7	267.7	278.5	292.8	306.3	329.7	365.0	414.4
144	115.0	386.1	285.0	296.5	311.7	326.1	351.0	388.6	441.2

Note 1: Based on 500A surge of 45μs time to crest through 84 kV MCOV, and 1kA surge of 45μs time to crest for MCOV ≤ 98kV.  
Note 2: For more detailed information on Polymer Station Arresters, refer to page 17.



**TEMPORARY OVERVOLTAGES**

Temporary overvoltages (TOV) can be caused by a number of system events such as line-to-ground faults, circuit backfeeding, load rejection and ferroresonance. The system configuration and operating practices should be reviewed to identify the most probable forms of temporary overvoltages which may occur at the arrester location. The arrester temporary overvoltage capability

must meet or exceed the expected temporary overvoltages. Table 3 defines the temporary overvoltage capability of each TRANQUELL arrester.

If detailed transient system studies or calculations are not available, it is traditional to consider as a minimum, the overvoltages due to single line-to-ground faults. The ar-

rester application standard ANSI C62.22 gives some guidance in determining the magnitude of single line-to-ground fault overvoltages. These overvoltages depend on details of system grounding.

<b>Table 2b Porcelain Station Arrester Characteristics</b>									
Rated Voltage kVrms	MCOV kVrms	0.5 μsec 10 kA Max IR-kVcrest	Switching Surge Maximum IR-kVcrest	8/20 Maximum Discharge Voltage - kVrest					
				1.5 kA	3 kA	5 kA	10 kA	20 kA	40 kA
3	2.55	9.1	6.3	6.9	7.2	7.5	8.0	9.0	10.3
6	5.10	17.9	12.4	13.6	14.2	14.8	15.8	17.7	20.3
9	7.65	26.6	18.4	20.2	21.1	22.0	23.5	26.4	30.2
10	8.40	29.3	20.3	22.2	23.3	24.2	25.9	29.1	33.3
12	10.2	35.5	24.6	26.9	28.2	29.4	31.4	35.2	40.4
15	12.7	44.2	30.6	33.5	35.1	36.6	39.1	43.9	50.3
18	15.3	53.3	36.8	40.4	42.3	44.1	47.1	52.8	60.6
21	17.0	59.1	40.9	44.8	46.9	48.9	52.3	58.7	67.2
24	19.5	67.8	46.9	51.4	53.8	56.1	60.0	67.3	77.1
27	22.0	76.5	52.9	58.0	60.8	63.3	67.7	75.9	87.0
30	24.4	84.9	58.7	64.3	67.4	70.3	75.1	84.2	96.5
36	29.0	101	69.7	76.4	80.0	83.4	89.2	100	115
39	31.5	110	75.8	83.0	86.9	90.6	96.9	109	125
45	36.5	128	88.3	96.8	102	106	113.0	127	146
48	39.0	136	93.8	103	108	113	120.0	135	155
54	42.0	135	98	105	112	115	122.0	136	151
60	48.0	154	110	120	127	131	139.0	155	173
66	53.0	170	122	132	140	145	153.0	171	191
72	57.0	183	131	142	151	156	165.0	184	205
90	74.0	236	169	185	195	202	214.0	237	266
96	76.0	242	175	190	201	208	220.0	245	274
108	88.0	279	202	219	232	239	254.0	284	316
120	98.0	311	231	244	257	266	283.0	315	351
132	106.0	340	249	264	280	289	306.0	342	381
144	115.0	368	271	287	303	314	332.0	369	413
168	131.0	418	308	326	345	357	379.0	421	470
172	140.0	446	330	348	368	381	404.0	448	502
180	144.0	458	339	359	380	392	417.0	463	517
192	152.0	483	360	379	401	414	440.0	488	546
228	180.0	571	424	447	474	489	520.0	578	645
240	194.0	615	457	482	511	527	560.0	623	695
258	209.0	665	516	522	552	571	604.0	670	752
264	212.0	675	523	527	558	576	613.0	680	760
276	220.0	700	545	547	578	597	635.0	705	788
288	234.0	743	578	582	615	636	676.0	753	839
294	237.0	753	585	589	623	644	685.0	762	849
300	243.0	772	600	604	639	661	702.0	782	871
312	253.0	778	605	609	644	666	708.0	788	878

Note 1: Based on 500A surge of 45μs time crest through 88 kV MCOV, 1kA surge of 45μs time to crest for 98kV ≥ MCOV ≥ 194 kV, and 2kA surge of 45μs time to crest for MCOV greater than 194kV.

Note 2: Special voltage ratings available upon request.



The primary effect of temporary overvoltages on metal oxide arresters is increased current and power dissipation, and a rising arrester temperature. Table 3 shows the temporary overvoltage capability of all GE arrester designs. This table defines the duration and magnitude of temporary overvoltages that may be applied to the arrester before

the arrester voltage must be reduced to the arresters' continuous operating voltage capability. These capabilities have been defined independent of system impedance and are therefore valid for voltages applied at the arrester location.

**SWITCHING SURGES**

The ability of TRANQUELL arresters to dissipate overhead line switching surges can be quantified to a large degree in terms of energy. The units used in quantifying the energy capability of metal oxide arresters is kilojoules per kilovolt. This is convenient as arresters are constructed of series repeating sections.

The maximum amount of energy that may be dissipated in TRANQUELL arresters is given in Table 4.

In defining these

capabilities, it is assumed that multiple discharges are distributed over a one-minute period. TRANQUELL arresters have considerably more capability in applications where the discharges take place over a longer period of time. After a one-minute rest period, the above discharges may be repeated. The one-minute rest period allows the disk temperature distribution to become uniform. Energy ratings also assume that switching surges occur in a system having surge impedance's of several hundred ohms as would be typical for overhead transmission circuits.

In low-surge impedance circuits having cables or shunt capacitors as elements, the energy capability of metal oxide arresters may be reduced because currents can exceed values stated previously.

The actual amount of energy discharged in a metal oxide arrester during a switching surge is a complex function of both the arrester volt-ampere characteristic and the details of the system. The energy likely to be discharged can best be determined on a Transient Network Analyzer (TNA) or with a digital circuit analysis program like the Electromagnetic Transients Program (EMTP) where system and arrester details can be represented accurately. GE's TNA II with its associated minicomputer data acquisition and analysis system or GE's MAN-TRAP program (enhanced version of EMTP) are uniquely well suited for these evaluations. Details of arrester modeling are included in the ARRESTER MODELING section of this brochure.

Duration (seconds)	Prior Duty <sup>1</sup>	Polymer (per unit of MCOV)				Porcelain (per unit of MCOV)
		Normal Heavy Duty Distribution	Riser Pole	Intermediate	Station	EHV Station (396 - 612kV)
0.02	No	1.75	1.58	1.58	1.61	1.56
0.1	No	1.64	1.52	1.52	1.55	1.52
1	No	1.57	1.43	1.43	1.47	1.45
10	No	1.49	1.37	1.37	1.39	1.38
100	No	1.43	1.32	1.32	1.34	1.32
1000	No	1.35	1.29	1.29	1.30	1.25
10000	No	--	1.27	1.27	1.28	1.18
0.02	Yes	1.73	1.56	1.56	1.56	1.49
0.01	Yes	1.62	1.49	1.49	1.50	1.45
1	Yes	1.55	1.41	1.41	1.42	1.38
10	Yes	1.47	1.35	1.35	1.36	1.32
100	Yes	1.40	1.31	1.31	1.32	1.26
1000	Yes	1.33	1.28	1.28	1.28	1.19
10000	Yes	--	--	--	1.27	1.13

<sup>1</sup>Prior duty energy levels as defined in Table 4

Arrester Rated Voltage (kVrms)	Housing Type	Arrester Type	Max. Current for Energy Rating (Amps)	kJ/kV of MCOV
3 - 36kV	Polymer	Normal Duty Distribution	300	1.4
3 - 36kV	Polymer	Heavy Duty Distribution	450	2.2
3 - 36kV	Polymer	Riser Pole	650	3.4
3 - 144kV	Polymer	Intermediate	650	3.4
3 - 144kV	Polymer	Station	1000	4.9
3 - 48kV	Porcelain	Station	1000	4.9
54 - 360kV	Porcelain	Station	1500	8.9
396 - 612kV	Porcelain	Station	2400	17.0



## Arrester Service Conditions and Other Considerations

### ARRESTER CONTAMINATION

TRANQUELL® arresters are built in accordance with contamination tests outlined in ANSI/IEEE C62.11. More demanding tests than those outlined in the ANSI/IEEE C62.11 have shown that TRANQUELL arresters have outstanding capability to withstand the effects of very severe external contamination.

In applications where severe contamination is anticipated and extra leakage (creepage) distance is required for other station insulation, the arrester leakage distance should be reviewed. An arrester connected line-to-ground needs to have a leakage distance no greater than that required for the other line-to-ground insulation in the station. Extra leakage distance arrester housings are available. Manual hot washing of TRANQUELL arresters with a single stream of pressurized, de-ionized water is permissible, provided electric utility industry accepted safety precautions are observed.

### ARRESTER FAILURE & PRESSURE RELIEF

In the event that the capability of a TRANQUELL arrester is exceeded, the metal oxide disks may crack or puncture. Such damage will reduce the arrester internal electrical resistance. Although this will limit the arrester's ability to survive future system conditions, it does not jeopardize the insulation protection provided by the arrester.

In the unlikely case of complete failure of the arrester, a line-to-ground arc will develop and pressure will build up inside the housing. This pressure will be safely vented to the outside and an external arc will be established provided the fault current is within the pressure relief fault current capability of the arrester. This low-voltage arc maintains equipment protection. All ratings of metal top porcelain station arresters will withstand a system available short circuit current of at least 65,000 amperes rms, symmetrical (169,000 amperes, first crest) in accordance with the test procedures outlined in ANSI/IEEE C62.11 and IEC 99.4. Porcelain arresters with higher pressure relief capability are available upon request. Pressure relief/fault current capability for all GE TRANQUELL arresters is shown in Table 5.

*Once an arrester has safely vented, it no longer possesses its pressure relief/fault current capability. An arrester that has vented should be replaced immediately.*

For a given application, the arrester to be selected should have a pressure relief/fault current capability greater than the maximum short-circuit current available at the intended arrester location including appropriate allowances for system growth. As with any porcelain arrester, the pressure relief apertures should be oriented away from adjacent apparatus to minimize damage to that apparatus in case of a pressure relief operation.

In applications where an arrester pressure relief/fault current capability is exceeded, it should be mounted in an enclosure to prevent a safety hazard. A physical installation of this nature might be used for the protection of a large generator.

### AMBIENT TEMPERATURE

Ambient temperature is an important consideration in the application of metal oxide arresters. Metal oxide materials exhibit a temperature dependent loss characteristic; the higher the ambient temperature, the higher will be the disk temperature when the arrester is operated at its continuous voltage capability.

The referenced standards indicate that the ambient temperature not exceeding 40°C is the standard service condition for arresters. TRANQUELL arresters are designed to operate at a weighted average temperature of 45°C with excursions to 60°C.

### ALTITUDE

TRANQUELL arresters are designed for altitudes not exceeding 10,000 ft. (3000 m) above sea level. For higher altitude applications, extra clearances may be required in the design of the arrester housing. In general, the insulation design of the substation will dictate the arrester clearances. For each 300 ft. (100 m) above a 10,000 ft. (3000 m) altitude, arrester clearances should increase approximately one percent [7].

### MOUNTING CONSIDERATIONS

TRANQUELL arresters are designed to be self-supporting for base mounting in a ver-

tical position. However, units for other mounting arrangements are available on request. Arresters may be horizontally mounted if the cantilever loading, including arrester weight, icing, and terminal loads, does not exceed the maximum working cantilever strength. Where applicable, the pressure relief vents should be located on the underside of the arrester. Units for suspension mountings are also available.

The rated working cantilever strengths for various arrester ratings are shown in Table 6 and are defined in accordance with ANSI C29.9 [8]. The defined strengths exceed the requirements for US Seismic Zone 3 (< 0.2g). For arresters installed in higher zones, seismic requirements need to be specified.

In the installation of arresters, recommended clearances between the arrester and any adjacent equipment must be observed. Failure to do so may result in unwanted flashovers and electrical overstress to internal arrester elements.

TRANQUELL arresters are designed to have a uniform voltage gradient along the length of the porcelain column. Where applicable, a grading ring is mounted on top of the arrester to establish a more uniform voltage distribution along the arrester. Clearly, if the arrester were mounted adjacent to a ground plane, this uniformity would be disturbed. To avoid such a situation, the minimum clearances to ground planes and other phase conductors must be observed.

### FIELD TESTING

In general, it is impractical to fully test an arrester in the field without high-voltage test equipment and accurate instrumentation. Instead, the arrester leakage current can be used to monitor the over-all state or condition of the arrester. For example, an abnormal leakage current measurement can be indicative of a wet, surface-contaminated, or vented arrester.

More information regarding field testing is available on the GE website ([www.ge.com/capacitor](http://www.ge.com/capacitor)).

Arrester leakage current can be monitored by a surge-counter leakage meter or by an oscilloscope connected directly to a surge-counter test connection. Typical arrester



leakage currents of station arresters operating at their continuous voltage capability and at 20°C are in the range of one-half to three milliamperes. Contamination of the arrester housing will contribute another component to the leakage current. If leakage current is to be used as an indication of arrester condition, the arrester must be clean, and the voltage and temperature must correspond to some standard test conditions,

specific to each arrester location.

**ARRESTER SELECTION SUMMARY**

The arrester selection process should include a review of all system stresses and service conditions expected at the arrester location. System stresses include continuous operating voltage, temporary overvoltages, and switching surges. If arresters of different ratings are required to meet these

individual criteria, the highest resulting rating must be chosen. The arresters' capability for contamination, pressure relief, ambient temperature, and altitude must exceed the specified requirements.

<b>Table 5- Pressure Relief / Fault Current</b>			
Arrester Rated Voltage (kVrms)	Housing Type	Arrester Type	Fault Current Capability (A sym.)
3 - 36kV	Polymer	Normal Duty Distribution	10,000
3 - 36kV	Polymer	Heavy Duty Distribution	20,000
3 - 36kV	Polymer	Riser Pole	20,000
3.0 - 144kV	Polymer	Intermediate	20,000
3.0 - 144kV	Polymer	Station	80,000
3.0 - 27kV	Porcelain	Station - Porcelain Top	10,000
3.0 - 48kV	Porcelain	Station - Metal Top	65,000
54 - 360kV	Porcelain	Station	93,000
396 - 612kV	Porcelain	Station	65,000

<b>Table 6 - Cantilever Strength</b>						
Arrester Rated Voltage (kVrms)	Housing Type	Arrester Type	Rated Ultimate Cantilever Strength		Maximum Working Cantilever Strength	
			in-lbs.	N-m	in-lbs.	N-m
3 - 36kV	Polymer	Normal Duty Distribution	1,500	169	600	68
3 - 36kV	Polymer	Heavy Duty Distribution	3,000	339	1,200	136
3 - 36kV	Polymer	Riser Pole	4,000	452	1,600	181
3 - 72kV	Polymer	Intermediate	4,000	452	2,000	226
90 - 144kV	Polymer	Intermediate	10,000	1,130	5,000	565
3 - 144kV	Polymer	Station	20,000	2,260	10,000	1,130
3 - 48kV	Porcelain	Station	70,000	7,909	28,000	3,163
54 - 360kV	Porcelain	Station	150,000	16,947	60,000	6,779
396 - 612kV	Porcelain	Station	200,000	22,596	80,000	9,038

## Insulation Coordination

Once an arrester has been selected, the protection it provides to the equipment insulation can be determined. This protection is dependent on the protective characteristics of the arrester, the lightning and switching surges expected on the system, and the insulation characteristics of the protected equipment. It is quantified in terms of the protective ratio which is the ratio of the equipment insulation withstand to the arrester protective level. The objective is to meet or exceed the minimum protective ratios for the various classes of voltage surges as recommended in the application standards. An alternate measure is the percent protective margin which is the protective ratio minus one, times 100 %. For example, a protective ratio of 1.53 corresponds to a 53 % protective margin.

### ARRESTER PROTECTIVE CHARACTERISTICS

The protective characteristic of TRANQUELL® arresters is solely defined by the discharge voltage and is generally proportional to arrester MCOV. For any one arrester, the discharge voltage is a function of the magnitude of the arrester current and, in the impulse region, of the time to crest of the arrester current. In general, for any specific applied impulse current through the arrester, the time-to-crest for the voltage wave will be less than the time-to-crest for the current wave. Figure 1 shows the test results of a 10 kA 8/20  $\mu$ s current impulse test.

TRANQUELL protective characteristics have been defined for fast impulse currents with times-to-crest shorter than 8  $\mu$ s. Available data on lightning strokes and simulation studies on impulse transients within substations both indicate that arresters in service may be subjected to fast current

impulse waves. To illustrate arrester protection for slower transients, the discharge voltages have been defined for standard switching surge currents.

The arrester protective characteristic is a continuous function defined over a range of discharge currents and their resultant discharge voltages. The insulation withstand of equipment on the other hand, is generally defined only at three voltage points through the use of the standard switching surge, the full wave, and the chopped wave tests. To facilitate comparison with these three withstands, three corresponding protective levels of the TRANQUELL arrester have been selected as indicated in Table 6.

Three protective levels are selected for coordination with the transformer insulation characteristics. They are described as follows:

- **Switching Surge Protective Level**

This is the crest discharge voltage that results when a 36/90  $\mu$ s current impulse is applied to the arrester. To define the arrester's switching surge protective level, a "switching surge coordination current" is defined for the various system voltages. These currents are: 500 amperes for maximum system line-to-line voltages to 150 kV, 1000 amperes for systems 151 to 325 kV, and 2000 amperes for systems above 325 kV.

- **Impulse Protective Level**

This is the crest discharge voltage that results when an 8/20  $\mu$ s current impulse is applied to the arrester. The resultant crest voltages for a variety of crest currents are given in the applicable Arrester Characteristics Table. To allow coordination with transformer insulation, a specific current impulse magnitude must be selected based on the system voltage. Reference [5] provides guidance for this selection.

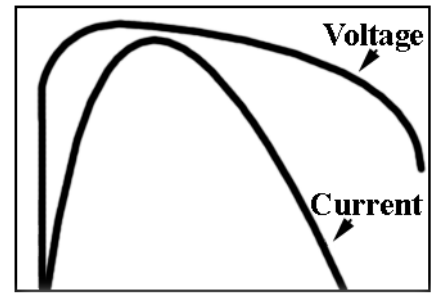

Figure 2. Arrester Voltage and current osillograms for 10kA, 8/20 $\mu$ s current impulse test.

- **Front-of-Wave Protective Level**

This is the discharge voltage for current impulses having a faster time to crest than the 8/20  $\mu$ s current impulse. This resultant crest voltage is listed as the front-of-wave (FOW) protective level. This protective level is derived by applying a series of current wave impulses to an arrester with varying times to crest (1, 2, 8 ms) and extending the measured voltages to 0.5  $\mu$ s in accordance with ANSI/IEEE C62.11.

### PROTECTIVE RATIOS

The three-point method is usually applied for insulation coordination. In this method the protective ratios are calculated at three separate points within the volt-time domain; namely switching surge, full wave, and chopped wave regions. If the following protective ratios are met or exceeded, satisfactory insulation coordination will be achieved according to the minimum recommendations given in ANSI C62.22.

These calculated protective ratios assume negligible arrester lead length and separation distance between the arrester and the transformer.

<u>Switching Surge Withstand</u>	$\geq 1.15$
Switching Surge Protective Level	
<u>Full Wave Withstand (BIL)</u>	$\geq 1.20$
Impulse Protective Level	
<u>Chopped Wave Withstand</u>	$\geq 1.25$
Front-of-Wave Protective Level	

In many cases, the calculated protective ratios exceed the minimum protective ratios recommended by ANSI by a considerable amount in actual power system applications.

As a specific example in protective ratio calculation, consider a 550kV BIL trans-

Transformer Insulation Withstand and Test Wave Description	Arrester Protective Level and Test Wave Description
Switching Surge (250/2500 $\mu$ s voltage wave)	Switching Surge (36/90 $\mu$ s current wave)
Full Wave (1.2/50 $\mu$ s voltage wave)	Impulse (8/20 $\mu$ s current wave)
Chopped Wave (1.2/50 $\mu$ s voltage wave)	Front-of-Wave (0.5 $\mu$ s current wave front)

former protected by a 144kV rated TRANQUELL polymer station surge arrester. The three transformer insulation withstand voltages are as specified in ANSI C57.12.00[9]. The calculated ratios indicate that the arrester would provide excellent protection for the transformer insulation.

If the separation distance between the transformer and arrester is not negligible, the transformer voltage can oscillate above the arrester voltage during lightning transients, thus reducing the protective ratio. Guidance in estimating these effects can be ob-

tained from ANSI C62.22 and References [10] and [11]. When making such transformer

voltage estimates for shielded stations, it is suggested that the front-of-wave protective level of the arrester be used as an approximation for the arrester voltage. In decisive situations, it is suggested that digi-

Transformer Withstand Tests	Transformer withstand voltages (kV)	Arrester Protective Levels (kV)	Protective Ratios
Switching Surge	460	285	1.61
Full Wave	550	351	1.57
Chopped Wave	630	386.1	1.63

tal computer studies be performed in which the arrester and substation details can be modeled.

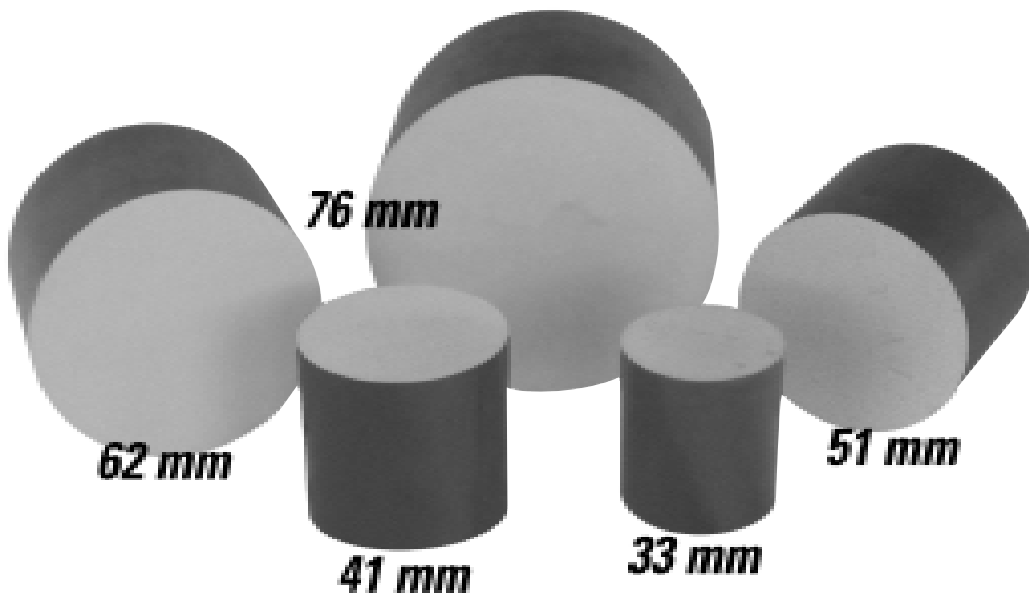

**World Class Disk Technology... The Heart of GE Arresters**

GE metal oxide disks are recognized for their leading edge technology by electrical equipment manufacturers around the world. Our disks have been incorporated in a broad array of products; surge arresters, under-oil protection in transformer tanks, cable termination products, switchgear and distribution panels and power quality devices. GE disks have more combined field experience in various arrester as well as non-arrester applications than any other disk available on the market today. Our disks are designed in accordance with IEEE and IEC Standards and are available in a voltage range from 3 to 6kV in five diametric sizes; 33mm, 41mm, 51mm, 62mm and 76mm.

Figure 3. GE Metal Oxide Disks

### Arrester Modeling

The TRANQUELL® arrester can be readily modeled for system studies. Typical voltage-current points for TRANQUELL arresters can be obtained via your local GE representative. The points are normalized on the arrester maximum discharge voltage at 10 kA and were generated by applying current waves of different magnitudes and times-to-crest to the arrester and measuring the resultant crest voltages. The maximum values are appropriate for the computation of protective ratios in insulation coordination and the minimum values may be used in computation of maximum arrester energies.

In studies involving switching surges, the 36/90  $\mu$ s volt-ampere relationship should be used to model the arrester. This type of model is sufficient for switching surges of longer duration. For lightning or fast switching surge studies, a conservative choice would be the use of the front-of-wave characteristic because it yields the highest calculated voltages and the lowest protective ratio. Depending on the actual waveforms, however, the 8/20  $\mu$ s characteristic may be an appropriate choice. In calculations involving ferroresonance or load rejection overvoltages, the power frequency characteristic (1 ms wavefront test data) could be used to determine the arrester volt-amp curve and the arrester duty.

It should be noted that when a metal oxide arrester is used to control temporary overvoltages that can last for many power frequency cycles, the material exhibits some time dependence. For a fixed amplitude, sinusoidal power frequency voltage applied to the metal oxide, the first few cycles of arrester current tend to be greater in magnitude than the subsequent cycles [12]. If the arrester is to be modeled for such an application, the specific volt-current-time relationship should be used.

#### APPLICATION OPPORTUNITIES

Because of their unique operating mode, high energy absorption, and low protective level, TRANQUELL arresters offer considerable advantages in a variety of situations where other types of arresters have been difficult to apply. Such situations include the protection of shunt capacitor

banks, cable circuits, switch-connected equipment, SF<sub>6</sub> substations and transmission lines.

#### SHUNT CAPACITOR BANK & CABLE CIRCUIT

The switching of shunt capacitor banks or cables can produce surges that may result in significant duty to arresters. This is particularly so if the switching device should restrike with trapped charge on the capacitor or cable. The arresters exposed to this duty may be located on either side of the switching device. TRANQUELL arresters limit the surge voltages by diverting the system current from the capacitor to the arrester. The duty imposed on the arrester depends on the size of the bank and the source impedance of the power system.

The application of arresters near large shunt capacitor banks generally requires an analytical investigation of the surge currents resulting from the switching and restriking of these capacitors. If an adjacent substation also has a shunt capacitor bank, the phenomenon of voltage magnification may cause higher surge currents in the remote arresters than in the arresters at the substation where the switching is being performed.

The application of TRANQUELL arresters on large capacitor banks should be reviewed with your local GE representative.

#### SWITCH CONNECTED EQUIPMENT

Equipment insulation can be subjected to high frequency, low energy transients initiated by some types of switchgear including air break switches. These transients have resulted in multiple operations and excessive power frequency energy in silicon carbide arresters. TRANQUELL arresters, however, maintain a higher average resistance during conduction, thus reducing the energy discharge and increasing the arrester's ability to survive.

#### SF<sub>6</sub> SUBSTATION PROTECTION

In SF<sub>6</sub> substations, particular concern is placed on the fast front protection of insulation within the station against lightning transients. In this role, TRANQUELL line entrance arresters offer an advantage under the fast impulse conditions of concern. By holding a lower voltage,

TRANQUELL arresters provide improved protection to the insulation within the substation remote from the arrester.

#### TRANSMISSION LINE SWITCHING SURGE PROTECTION

TRANQUELL arresters connected to the open-end of switched lines can reduce the magnitude of switching surges along the entire line. Such an application can result in more reliable operation or, in the case of new lines, a possible reduction in the cost of line insulation and a smaller right of way. Further reduction in switching surges are possible with additional arresters at intermediate locations.



Figure 4. TRANQUELL Polymer Station Arrester



## Extra High Voltage (EHV) Arresters

### DESCRIPTION

TRANQUELL® Extra High Voltage surge arresters have provided excellent protective characteristics, temporary overvoltage capability and switching-surge energy withstand to power systems of 500kV and above for over 20 years. It is an improvement on the field-proven TRANQUELL arrester and incorporates the latest development in metal-oxide technology and outdoor arrester design.

The TRANQUELL Extra High Voltage surge arrester consists basically of two parallel columns of highly non-linear metal oxide resistors, which are hermetically enclosed in porcelain containers. Each column is comprised of metal oxide disks connected in series. The discharge current, and thus the energy, is essentially equally distributed between the two columns. The improved metal oxide disks have better volt-ampere characteristics, lower power dissipation, and a non-porous glass-ceramic insulating collar around the disk which ensures long-term stability in any environment. The new porcelain housing's shed profile has outstanding capability to withstand the effects of very severe external contamination.

Since TRANQUELL Extra High Voltage surge arresters do not have series or shunt gaps, the reliability of the arrester is enhanced: there is no sparkover protective characteristics, no gap reseal requirement, and no gap failure due to pollution-induced coupling currents. Also, the response time of the arrester to overvoltages is extremely fast. At normal system voltage, the arrester conducts a very small amount of current; when a surge reaches the arrester, it instantaneously conducts the current necessary to limit the overvoltage. As a result, TRANQUELL arresters absorb minimum energy to protect equipment insulation.

TRANQUELL Extra High Voltage surge arresters are designed to meet or exceed the requirements of ANSI/IEEE C62.11-

1993 and IEC 99-4 (1991) standards.

The designs for the standard TRANQUELL Extra High Voltage surge arresters for various ratings and recommended system voltages are listed in Table 10. Arresters of special design can be built to meet particular application requirements.

### EHV ENERGY CAPABILITY

The ability of the TRANQUELL arrester to dissipate system switching surges can be quantified to a large degree in terms of energy. The units generally used in quantifying this capability are "kilojoules per kV (kJ/kV) of rating" or "kilojoules per kV of MCOV". This is convenient since the various arrester ratings are constructed using series arrester units. The maximum amount of energy that a TRANQUELL Extra High Voltage arrester can absorb in a single event, without damage to the arrester or change in its performance, is 13.6 kJ/kV of rating or 17.0 kJ/kV of MCOV. In defining this capability, the impulse energy is assumed to take place as a single discharge or multiple discharges within a very short period without a pause for cooling. The arresters have considerably more capability in applications where the discharges may take place over a longer period of time.

To provide assurance that all metal-oxide disks used in TRANQUELL arresters have this capability, every disk is subjected to a disk strength test series consisting of three groups of multiple energy discharges. Each group is applied within one minute and the disk is allowed to cool between each group. The total rated test energy applied to each disk in one group is 15.5 kJ/kV of rating or 19.4 kJ/kV of MCOV. For TRANQUELL Extra High Voltage arresters with two parallel columns of metal oxide disks, the rated test energy is 29.5 kJ/kV of rating or 36.8 kJ/kV of MCOV.

Although the statement of arrester energy capability is quite succinct, the actual

amount of energy discharged into an arrester during a system switching surge is a complex function of both the arrester impedance and the details of the network or system. The energy likely to be discharged can be determined on a Transient Network Analyzer (TNA) or by computer simulation where system and arrester details are represented.

For applications requiring higher energy capability or lower protective levels, or both, than the standard ratings, special TRANQUELL Extra High Voltage can be designed. In fact, GE has supplied such arrester designs that are utilized to protect Extra High Voltage circuit breakers and large capacitor installations.

## Arrester Service Conditions and Other Considerations

### EHV CONTAMINATION PERFORMANCE

The TRANQUELL arrester easily passes the ANSI/IEEE C62.11 contamination test. More demanding tests, for example the 20-cycle 7-hour slurry test prescribed by BPA, AEP and NYPA, indicate that the TRANQUELL arrester has outstanding capability to withstand the effects of very severe external contamination.

### SEISMIC REQUIREMENTS

Standard TRANQUELL Extra High Voltage arresters are designed and tested to withstand the requirements of seismic Zone 3 of the United States. Arresters with higher seismic withstand capability are available.

### MOUNTING CONSIDERATIONS

TRANQUELL Extra High Voltage arresters are designed to be self-supporting for base mounting in a vertical position. The rated cantilever strength of the standard arresters is 200,000 in-lb (22,600 Nm).

Table 9 - Standard TRANQUELL Extra High Voltage Arresters

Maximum System Voltage*, kVrms	550	550	550	800	800
Arrester Rating, kVrms	396	420	444	588	612
Maximum Continuous Operating Voltage (MCOV), kVrms	318	335	353	470	485
1-sec. Temporary Overvoltage Capability, kVrms	467	496	524	694	722
Max. Equivalent Front-of-Wave Protective Level, kVcrest	1017	1075	1129	1548	1597
Maximum Discharge Voltage, kVcrest, with 8/20 $\mu$ s Current Wave					
at 1.5kA	772	816	857	1141	1177
at 3.0kA	804	849	892	1187	1225
at 5.0kA	827	874	928	1223	1261
at 10kA	869	918	964	1284	1324
at 15kA	897	948	995	1325	1367
at 20kA	919	971	1020	1358	1401
at 40kA	1019	1076	1130	1505	1553
Maximum Discharge Voltage, kVcrest, with 36/90 $\mu$ s Current Wave					
at 1000A	738	780	819	1090	1125
at 2000A	763	806	847	1127	1163
at 3000A	779	823	865	1152	1188
Creepage Distance of porcelain housing, in.					
Single-impulse energy capability	400	432	444	565	565
kJ/kV of rating		13.6	13.6	13.6	13.6
kJ/kV of MCOV	13.6	17	17	17	17
Rated test energy of factory routine test (3 discharges in oneminute)	17				
kJ/kV of rating	29.5	29.5	29.5	29.5	29.5
kJ/kV of MCOV	36.8	36.8	36.8	36.8	36.8
Type of housing	Porcelain	Porcelain	Porcelain	Porcelain	Porcelain
Color of housing	ANSI#70 gray	ANSI#70 gray	ANSI#70 gray	ANSI#70 gray	ANSI#70 gray
Radio influence voltage, mV (max.)	25	25	25	25	25
Insulation withstand of arrester housing:					
Lightning impulse voltage withstand, kVpeak	1675	1800	1950	2100**	2100**
Switching impulse voltage withstand, kVpeak	1175	1175	1300	1425**	1425**
Pressure relief capability, kA rms sym (0.2s)	65	65	65	65	65
Weight, lb.	2360	2460	2780	3840	3920

Notes: \* The network or power system is assumed to be solidly grounded  
 \*\* The arrester housing has higher insulation withstand levels than these values, which are the test levels used during the actual tests



Figure 5. TRANQUELL EHV Arresters



# Polymer Station & Intermediate Arresters

GE's surge arresters are designed to protect against overvoltages such as lightning or switching. Station Class arresters are used in large electric utility and industrial substations to protect transformers

and other substation equipment from lightning and switching surge generated overvoltages. Intermediate Class arresters are used where the purchaser feels that the higher cost of Station Class ar-

resters is not justified. TRANQUELL® polymer arresters provide both excellent protective characteristics and temporary overvoltage capability.

## STATION ARRESTER INSULATION CHARACTERISTICS\*

Rated Voltage (kVrms)	Creep	Strike	Minimum 1.2 x 50 $\mu$ s Withstand (kVcrest)	Minimum Power Frequency (kV rms)	
	in [mm]	in [mm]		Wet (10 sec)	Dry (1 min)
3	23 [584]	8.9 [225]	120	57	88
6	23 [584]	8.9 [225]	120	57	88
9	23 [584]	8.9 [225]	120	57	88
10	23 [584]	8.9 [225]	120	57	88
12	31 [787]	11.4 [290]	161	74	113
15	31 [787]	11.4 [290]	161	74	113
18	31 [787]	11.4 [290]	161	74	113
21	46 [1168]	16.5 [420]	241	109	163
24	46 [1168]	16.5 [420]	241	109	163
27	46 [1168]	16.5 [420]	241	109	163
30	46 [1168]	16.5 [420]	241	109	163
36	62 [1575]	21.7 [550]	321	145	213
39	62 [1575]	21.7 [550]	321	145	213
45	62 [1575]	21.7 [550]	321	145	213
48	62 [1575]	21.7 [550]	321	145	213
54	78 [1981]	27.0 [685]	401	182	264
60	78 [1981]	27.0 [685]	401	182	264
66	78 [1981]	27.0 [685]	401	182	264
72	124 [3150]	42.1 [1070]	639	295	415
90	124 [3150]	33.3 [845]	499	228	326
96	124 [3150]	33.3 [845]	499	228	326
108	156 [3962]	43.3 [1100]	660	306	428
120	156 [3962]	43.3 [1100]	660	306	428
132	186 [4724]	53.7 [1365]	817	385	530
144	186 [4724]	53.7 [1365]	817	385	530

\*Station Arrester Characteristics are shown on pg. 7

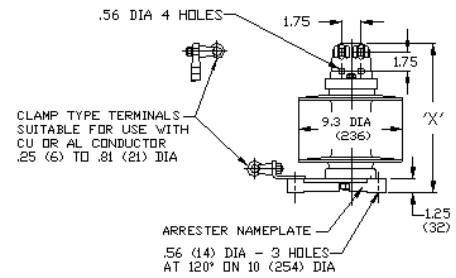

Figure 6. Polymer Station Arrester, 3kV through 72kV

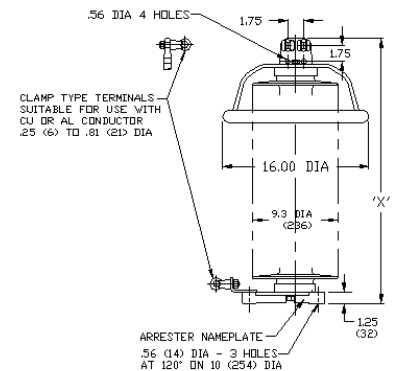

Figure 7. Polymer Station Arrester - 90kV through 144kV (Hardware and base dimensions are same as in Figure 6)

## STATION ARRESTER DIMENSIONS, LEAKAGE DISTANCES, MOUNTING CLEARANCES & WEIGHTS

Rated Voltage (kV)	MCOV kVrms	"X" Overall Height (NEMA Pad) in [mm]	"X" Overall Height (Eyebolt Terminal) in [mm]	Mounting Clearance (1)		Center Line to Center Line in [mm]	Center Line to Ground in [mm]	Weight [NEMA Pad] lb [kg]	Weight [Eyebolt Terminal] lb [kg]
				Leakage Distance Terminal to Base in [mm]	Center Line to Center Line in [mm]				
3	2.55	13.7 [348]	10.2 [259]	23 [584]	12.3 [312]	7.7 [196]	22 [10.0]	20.3 [9.2]	
6	5.10	13.7 [348]	10.2 [259]	23 [584]	12.3 [312]	7.7 [196]	23 [10.4]	20.8 [9.4]	
9	7.65	13.7 [348]	10.2 [259]	23 [584]	12.3 [312]	7.7 [196]	24 [10.9]	21.3 [9.7]	
10	8.40	13.7 [348]	10.2 [259]	23 [584]	12.3 [312]	7.7 [196]	24 [10.9]	21.6 [9.8]	
12	10.2	16.4 [417]	12.8 [325]	31 [787]	12.3 [312]	7.7 [196]	27 [12.2]	25.2 [11.4]	
15	12.7	16.4 [417]	12.8 [325]	31 [787]	12.3 [312]	7.7 [196]	28 [12.7]	25.8 [11.7]	
18	15.3	16.4 [417]	12.8 [325]	31 [787]	12.3 [312]	7.7 [196]	28 [12.7]	26.3 [11.9]	
21	17.0	21.7 [551]	18.2 [462]	46 [1168]	12.3 [312]	7.7 [196]	36 [16.3]	33.6 [15.2]	
24	19.5	21.7 [551]	18.2 [462]	46 [1168]	12.3 [312]	8.0 [203]	36 [16.3]	34.2 [15.5]	
27	22.0	21.7 [551]	18.2 [462]	46 [1168]	12.3 [312]	8.8 [224]	37 [16.8]	34.7 [15.7]	
30	24.4	21.7 [551]	18.2 [462]	46 [1168]	12.3 [312]	9.6 [244]	37 [16.8]	35.2 [16.0]	
36	29.0	27.0 [686]	23.5 [597]	62 [1575]	13.8 [351]	11.0 [279]	45 [20.4]	43.0 [19.5]	
39	31.5	27.0 [686]	23.5 [597]	62 [1575]	14.6 [371]	11.8 [300]	46 [20.8]	43.5 [19.7]	
45	36.5	27.0 [686]	23.5 [597]	62 [1575]	16.3 [414]	13.5 [343]	45 [20.8]	44.4 [20.1]	
48	39.0	27.0 [686]	23.5 [597]	62 [1575]	17.0 [432]	14.2 [361]	47 [21.3]	45.2 [20.5]	
54	42.0	32.4 [823]	28.8 [731]	78 [1981]	18.6 [472]	15.8 [401]	55 [24.9]	52.6 [23.9]	
60	48.0	32.4 [823]	28.8 [731]	78 [1981]	20.6 [523]	17.8 [452]	56 [25.4]	53.6 [24.0]	
66	53.0	32.4 [823]	28.8 [731]	78 [1981]	22.6 [574]	19.2 [488]	57 [25.9]	54.6 [24.8]	
72	57.0	48.2 [1224]	44.6 [1133]	124 [3150]	23.4 [594]	20.6 [523]	79 [35.8]	76.7 [34.8]	
90	70.0	48.2 [1224]	44.6 [1133]	124 [3150]	39.2 [996]	31.2 [792]	85 [38.5]	82.5 [37.4]	
96	76.0	48.2 [1224]	44.6 [1133]	124 [3150]	41.0 [1041]	33.0 [838]	86 [39.0]	84.2 [38.2]	
108	84.0	58.8 [1494]	55.3 [1405]	156 [3962]	44.5 [1130]	36.5 [927]	101 [45.8]	98.9 [44.9]	
120	98.0	58.8 [1494]	55.3 [1405]	156 [3962]	49.0 [1245]	41.0 [1041]	103 [46.7]	101.0 [45.8]	
132	106.0	69.3 [1760]	65.8 [1671]	186 [4724]	53.0 [1346]	45.0 [1143]	120 [54.4]	117.6 [53.3]	
144	115.0	69.3 [1760]	65.8 [1671]	186 [4724]	56.0 [1422]	48.0 [1219]	122 [55.3]	120.1 [54.5]	



## GE Surge Arresters

# Polymer Intermediate Arrester

### PROTECTIVE CHARACTERISTICS

Rated Voltage kVrms	MCOV kVrms	0.5 µsec 10 kA Max IR- kVcrest	500A Switching Surge Maximum IR-kVcrest	8/20 Maximum Discharge Voltage (kV Crest)					
				1.5 kA	3 kA	5 kA	10 kA	20 kA	40 kA
3	2.6	8.7	6.0	6.5	7.0	7.4	8.1	9.0	10.6
6	5.1	17.4	12.0	13.0	14.0	14.7	16.2	18.1	21.1
9	7.7	25.7	18.0	19.3	21.0	21.9	24.0	27.0	31.6
10	8.4	28.5	19.0	21.2	23.0	24.0	26.5	29.8	34.8
12	10.2	34.8	23.0	25.9	28.0	29.4	32.3	36.2	42.2
15	12.7	43.1	29.0	32.3	35.0	36.6	40.2	45.1	52.7
18	15.3	51.4	35.0	38.6	41.9	43.8	48.0	54.0	63.2
21	17.0	57.6	39.0	42.8	46.4	48.6	53.6	60.2	70.5
24	19.5	68.8	47.0	51.6	55.9	58.5	64.2	72.1	84.3
27	22.0	77.1	52.0	57.9	62.9	65.7	72.0	81.0	94.8
30	24.4	85.5	58.0	63.5	69.0	72.0	79.5	89.4	104.4
36	29.0	102.8	70.0	77.2	83.8	87.6	96.0	108.0	126.6
39	31.5	114.0	76.0	84.8	92.0	96.0	106.0	119.2	139.2
45	36.5	128.5	90.0	96.5	105.0	109.5	120.0	135.0	158.0
48	39.0	142.5	96.0	106.0	115.0	120.0	132.5	149.0	174.0
54	42.0	154.2	105.0	115.8	126.0	131.4	144.0	162.0	189.6
60	48.0	171.0	115.2	127.2	138.0	144.0	159.0	178.8	208.8
72	57.0	199.5	134.4	148.4	161.0	168.0	185.5	208.6	243.6
90	70.0	253.0	175.0	192.0	209.0	217.0	240.0	268.0	312.0
96	76.0	270.0	187.0	205.0	223.0	232.0	256.0	286.0	333.0
108	88.0	314.0	217.0	238.0	259.0	270.0	302.0	332.0	386.0
120	98.0	341.0	236.0	258.0	282.0	293.0	322.0	360.0	420.0
132	106.0	381.0	263.0	288.0	312.0	327.0	360.0	402.0	468.0
144	115.0	405.0	280.2	306.0	333.0	348.0	384.0	429.0	498.0



Figure 8. TRANQUELL Polymer Intermediate Arrester

### INSULATION CHARACTERISTICS

Rated Voltage (kV)	MCOV kVrms	Creep in [mm]	Strike in [mm]	Minimum 1.2 x 50 µs Withstand (kV Crest)	Minimum Power Frequency (kV rms)	
					Wet (10sec)	Dry (1sec)
3	2.6	15.4 [391.2]	5.6 [142.2]	100	40	60
6	5.1	15.4 [391.2]	5.6 [142.2]	100	40	60
9	7.7	15.4 [391.2]	5.6 [142.2]	100	40	60
10	8.4	15.4 [391.2]	5.6 [142.2]	100	40	60
12	10.2	30.8 [782.3]	10.8 [274.3]	165	70	100
15	12.7	30.8 [782.3]	10.8 [274.3]	165	70	100
18	15.3	30.8 [782.3]	10.8 [274.3]	165	70	100
21	17.0	30.8 [782.3]	10.8 [274.3]	165	70	100
24	19.5	46.2 [1173.5]	16.1 [408.9]	230	105	140
27	22.0	46.2 [1173.5]	16.1 [408.9]	230	105	140
30	24.4	46.2 [1173.5]	16.1 [408.9]	230	105	140
36	29.0	61.6 [1564.6]	21.3 [541.0]	310	140	180
39	31.5	61.6 [1564.6]	21.3 [541.0]	310	140	180
45	36.5	77.0 [1955.8]	26.5 [673.1]	390	180	230
48	39.0	77.0 [1955.8]	26.5 [673.1]	390	180	230
54	42.0	92.4 [2347.0]	31.7 [805.2]	450	220	260
60	48.0	92.4 [2347.0]	31.7 [805.2]	450	220	260
72	57.0	107.8 [2738.1]	37.0 [939.8]	520	250	300
90	70.0	108.0 [2743.2]	43.3 [1099.8]	580	320	400
96	76.0	108.0 [2743.2]	43.3 [1099.8]	580	320	400
108	88.0	108.0 [2743.2]	43.3 [1099.8]	580	320	400
120	98.0	162.0 [4114.0]	56.1 [1424.9]	831	335	543
132	106.0	162.0 [4114.0]	56.1 [1424.9]	831	335	543
144	115.0	162.0 [4114.0]	56.1 [1424.9]	831	335	543



# Polymer Intermediate Arrester

## INTERMEDIATE ARRESTER DIMENSIONS, LEAKAGE DISTANCES, MOUNTING CLEARANCES & WEIGHTS [NEMA PAD]

MCOV	"X" Overall Height	Mounting Clearance (1)			Weight
		Leakage Distance Terminal to Base	Center Line to Center Line	Center Line to Ground	
kV	in [mm]	in [mm]	in [mm]	in [mm]	lb
2.55	10.3 [262.6]	15.4 [391.2]	9.5 [241.3]	5.5 [139.7]	6.3 [2.9]
5.10	10.3 [262.6]	15.4 [391.2]	9.5 [241.3]	5.5 [139.7]	6.3 [2.9]
7.65	10.3 [262.6]	15.4 [391.2]	9.5 [241.3]	5.5 [139.7]	6.3 [2.9]
8.40	10.3 [262.6]	15.4 [391.2]	9.5 [241.3]	5.5 [139.7]	6.3 [2.9]
10.2	15.6 [397.3]	30.8 [782.3]	9.5 [241.3]	5.5 [139.7]	10.0 [4.5]
12.7	15.6 [397.3]	30.8 [782.3]	9.5 [241.3]	5.5 [139.7]	10.0 [4.5]
15.3	15.6 [397.3]	30.8 [782.3]	9.5 [241.3]	5.8 [147.3]	10.0 [4.5]
17.0	15.6 [397.3]	30.8 [782.3]	9.5 [241.3]	6.8 [172.7]	10.0 [4.5]
19.5	19.7 [501.4]	46.2 [1173.5]	9.5 [241.3]	7.8 [198.1]	13.7 [6.2]
22.0	19.7 [501.4]	46.2 [1173.5]	10.5 [266.7]	8.8 [223.5]	13.7 [6.2]
24.4	19.7 [501.4]	46.2 [1173.5]	10.5 [266.7]	8.8 [223.5]	13.7 [6.2]
29.0	26.4 [671.6]	61.6 [1564.6]	12.5 [317.5]	10.8 [274.3]	17.4 [7.9]
31.5	26.4 [671.6]	61.6 [1564.6]	13.5 [342.9]	11.8 [299.7]	17.4 [7.9]
36.5	31.8 [808.7]	77.0 [1955.8]	15.5 [393.7]	13.8 [350.52]	20.0 [9.1]
39.0	31.8 [808.7]	77.0 [1955.8]	16.5 [419.1]	14.8 [375.9]	20.0 [9.1]
42.0	35.9 [912.9]	92.4 [2347.0]	18.5 [469.9]	16.8 [426.7]	23.5 [10.7]
48.0	35.9 [912.9]	92.4 [2347.0]	20.5 [520.7]	18.8 [477.5]	23.5 [10.7]
57.0	42.6 [1083.1]	107.8 [2738.1]	23.5 [596.9]	21.8 [553.7]	27.0 [12.2]
70.0	47.6 [1209]	108.0 [2743.2]	40.0 [1016.0]	33.0 [838.2]	55.0 [25.0]
76.0	47.6 [1209]	108.0 [2743.2]	42.0 [1066.8]	35.0 [889.0]	56.0 [25.4]
88.0	47.6 [1209]	108.0 [2743.2]	46.0 [1168.4]	39.0 [990.6]	57.0 [25.9]
98.0	70.1 [1780]	162.0 [2743.2]	51.0 [1295.4]	44.0 [1117.6]	70.5 [32.0]
106.0	70.1 [1780]	162.0 [2743.2]	55.0 [1397.0]	47.0 [1193.8]	70.5 [32.0]
115.0	70.1 [1780]	162.0 [2743.2]	58.0 [1473.2]	50.0 [1270.0]	70.5 [32.0]

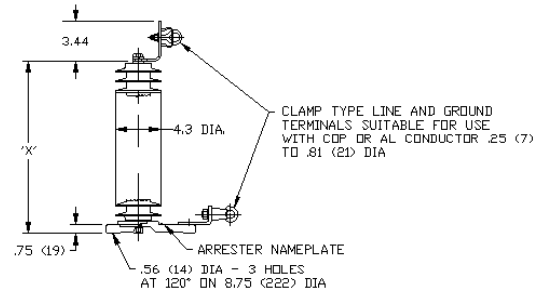

Figure 9. Polymer Intermediate Arrester, 3kV through 72kV [9L12PPAXXS]

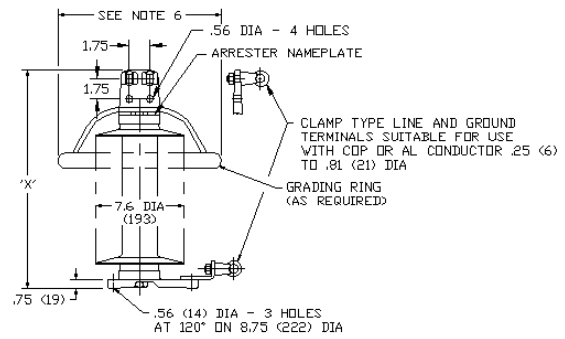

Figure 10. Polymer Intermediate Arrester, 90kV through 144kV [9L12PPAXXS]

## INTERMEDIATE ARRESTER DIMENSIONS, LEAKAGE DISTANCES, MOUNTING CLEARANCES & WEIGHTS [EYEBOLT TERMINAL]

MCOV	"X" Overall Height	Mounting Clearance (1)			Weight
		Leakage Distance Terminal to Base	Center Line to Center Line	Center Line to Ground	
kV	in [mm]	in [mm]	in [mm]	in [mm]	lb [kg]
2.55	6.9 [175.3]	15.4 [391.2]	9.5 [241.3]	5.5 [139.7]	6.3 [2.9]
5.10	6.9 [175.3]	15.4 [391.2]	9.5 [241.3]	5.5 [139.7]	6.3 [2.9]
7.65	6.9 [175.3]	15.4 [391.2]	9.5 [241.3]	5.5 [139.7]	6.3 [2.9]
8.40	6.9 [175.3]	15.4 [391.2]	9.5 [241.3]	5.5 [139.7]	6.3 [2.9]
10.2	12.2 [309.9]	30.8 [782.3]	9.5 [241.3]	5.5 [139.7]	10.0 [4.5]
12.7	12.2 [309.9]	30.8 [782.3]	9.5 [241.3]	5.5 [139.7]	10.0 [4.5]
15.3	12.2 [309.9]	30.8 [782.3]	9.5 [241.3]	5.8 [147.3]	10.0 [4.5]
17.0	12.2 [309.9]	30.8 [782.3]	9.5 [241.3]	6.8 [172.7]	10.0 [4.5]
19.5	16.3 [414.0]	46.2 [1173.5]	9.5 [241.3]	7.8 [198.1]	13.7 [6.2]
22.0	16.3 [414.0]	46.2 [1173.5]	10.5 [266.7]	8.8 [223.5]	13.7 [6.2]
24.4	16.3 [414.0]	46.2 [1173.5]	10.5 [266.7]	8.8 [223.5]	13.7 [6.2]
29.0	23.0 [584.2]	61.6 [1564.6]	12.5 [317.5]	10.8 [274.3]	17.4 [7.9]
31.5	23.0 [584.2]	61.6 [1564.6]	13.5 [342.9]	11.8 [299.7]	17.4 [7.9]
36.5	28.4 [721.4]	77.0 [1955.8]	15.5 [393.7]	13.8 [350.52]	20.0 [9.1]
39.0	28.4 [721.4]	77.0 [1955.8]	16.5 [419.1]	14.8 [375.9]	20.0 [9.1]
42.0	32.5 [825.5]	92.4 [2347.0]	18.5 [469.9]	16.8 [426.7]	23.5 [10.7]
48.0	32.5 [825.5]	92.4 [2347.0]	20.5 [520.7]	18.8 [477.5]	23.5 [10.7]
57.0	39.2 [995.7]	107.8 [2738.1]	23.5 [596.9]	21.8 [533.7]	27.0 [12.2]

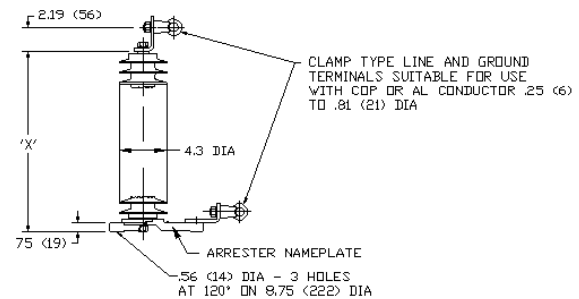

Figure 11. Polymer Intermediate Arrester, 3kV through 72kV [9L12PPBXXS]



## Polymer Distribution & Riser Pole Arresters

GE Tranquell Polymer Distribution and Riser Pole surge arresters are used on distribution systems to protect transformers and other medium voltage power equipment from lightning and switching surge generated overvoltages. The Polymer Distribution and Riser pole arresters exhibit excellent protective characteristics, temporary overvoltage capability, and switching surge energy withstand. Gapless internal construction combined with a polymer housing results in a design which

is simple, reliable, and economical while offering excellent fault current capability to meet the most demanding service conditions. The GE arrester design is based on field-proven metal oxide disks known for maintaining stable characteristics. In order to assure the highest level of quality, Tranquell Polymer Distribution and Riser Pole surge arresters are designed and manufactured in accordance with the latest versions of ANSI/IEEE C62.11 and IEC 99-4.



Figure 12. TRANQUELL Polymer Riser Pole Arrester

### BASIC CONSTRUCTION

The metal oxide column is centered and restrained in alignment with tightly woven fiberglass filament strands impregnated with epoxy resin. The interstices between the stranding are filled with a silicone dielectric material so the design is free of air and moisture. The inside diameter of the housing is slightly smaller than the outside diameter of the cylindrical element providing a snug fit.

For a typical 10kV rated arrester, the basic polymer housing is only six inches long — 50 to 60 percent shorter than the porcelain equivalent. Likewise, the ar-

resters are less than half the weight of an equivalent porcelain housed arrester. This makes transportation, handling, and installation much easier.

Another significant advantage of the GE TRANQUELL polymer arrester construction is that fault withstand capability can be maintained throughout the voltage range. The fault current capability of porcelain housed arresters is reduced as the housing lengthens.

The polymer housed arrester can be used with all standard mounting arms and brackets. They come with all the necessary fasteners, isolators and terminal

attachments. A specially designed glass-filled polyester insulating arm extends from the arrester to the NEMA crossarm bracket, eliminating the need for installation of a metal clamping band around the arrester. The insulating arm not only eliminates the rust and corrosion sometimes encountered with a metal clamping band, but also has been treated with an inhibitor to resist ultraviolet damage.

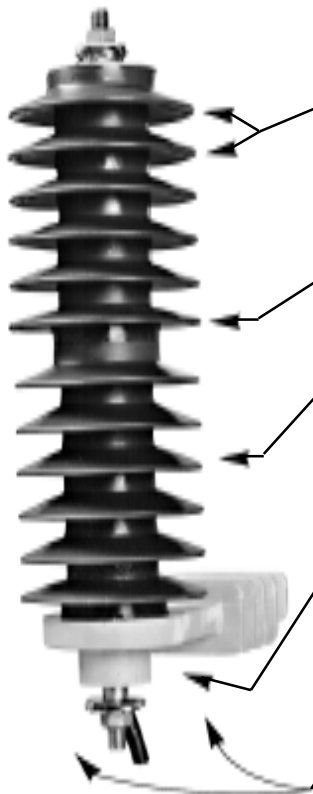

GE'S POLYMER CONSTRUCTION provides excellent contamination performance that meets or exceeds ANSI/IEEE contamination test requirements. The arrester housing is made of ESP silicone alloy weathershed material that resists tracking from surface leakage currents. ESP's excellent properties have been confirmed through a series of industry standard performance tests that include tracking resistance, contamination, accelerated aging and seal integrity.

WHEN EXPOSED TO HIGH FAULT CURRENTS the epoxy/fiberglass wrapped modules either rupture or burn through to relieve internal pressure. The polymer housings then split to relieve the pressure.

POLYMER ARRESTERS are not susceptible to cracking or breaking like porcelain arresters, so the possibility of damage from mishandling in packing, shipping and installation is virtually eliminated. The risk of damage from vandalism is also greatly reduced. The polymer housing material excels in tolerance to weather extremes from desert heat to arctic cold, and resists damage from ultraviolet rays and ozone. Samples of the polymer have survived the equivalent of over 50 years of accelerated ultraviolet testing.

USING OPTIMUM CONNECTION METHODS for the arrester leads is important in reducing surge voltage stress. Placing the ground connection of the transformer just under the crossarm where the arrester ground leads meet the pole ground reduces surge voltage stress. Many pole mounted transformer installations use arresters mounted on the crossarm. Such installations tend to have very long arrester leads that increase surge voltage stress on transformer windings. Arrester lead is the combined length of line and ground lead wire in series with the arrester and in parallel with the protected device (transformer in this case).

THE POLYMER ARRESTERS ARE LESS THAN HALF THE WEIGHT of an equivalent porcelain arrester. This lighter weight makes transportation, handling and installation much easier. The basic polymer housing is only 6 inches long for a typical 10kV rated arrester. The polymer housing is 50 to 60% shorter than the housing of an equivalent porcelain arrester.

Figure 13. TRANQUELL Polymer Heavy-Duty Distribution Arrester



### Porcelain Metal Top Station Arrester

Rated Voltage	MCOV	"x" Overall Height		Weight		Leakage Distance Terminal to Base		Strike		Mounting Clearance (1)				Minimum 2 x 50u Withstand (kV crest)	Minimum Power Frequency Withstand (kVrms)	
										Phase to Phase		Phase to Ground			Wet (10 sec)	Dry (1 min)
kV	kV	inches	mm	lb.	kg	in	mm	in	mm	in	mm	in.	mm	(kV crest)	Wet (10 sec)	Dry (1 min)
3	2.55	19.1	485	65	29.4	6.2	157	4.5	114	12	305	6	152	60	20	21
6	5.1	19.1	485	65	29.4	6.2	157	4.5	114	12	305	7	177	75	24	27
9	7.65	19.1	485	66	29.9	6.2	157	4.5	114	13	330	7	177	95	30	35
10	8.4	19.1	485	66	29.9	6.2	157	4.5	114	13	330	8	203	95	30	35
12	10.2	21.1	536	72	32.6	11.1	282	6.1	155	14	356	8.5	216	110	45	50
15	12.7	21.1	536	73	33	11.1	282	6.1	155	14	356	8.5	216	110	45	50
18	15.3	24.1	612	80	36.2	20	508	9.1	231	16	406	9	229	110	45	50
21	17.0	24.1	612	81	36.7	20	508	9.1	231	16	406	9	229	150	60	70
24	19.5	24.1	612	82	37	20	508	9.1	231	17	432	11	279	150	60	70
27	22.0	28.1	714	90	40.7	31.7	805	13.5	343	18	457	12	305	150	60	70
30	24.4	28.1	714	91	41.2	31.7	805	13.5	343	18	457	12	305	200	80	95
36	29.0	28.1	713.7	93	42.1	31.7	805	13.5	343	20	508	14	356	200	80	95
39	31.5	31.9	810	105	47.5	41	1041	17.25	438	21	533	14	356	250	100	120
45	36.5	31.9	810	107	48.4	41	1041	17.25	438	21	533	15	381	250	100	120
48	39	31.9	810	109	49.3	41	1041	17.25	438	22	559	15	381	250	100	120
54	42	38.1	968	180	81.4	60	1524	23.25	591	24	610	18	457	194	81	See Note 2
60	48	38.1	968	185	83.7	60	1524	23.25	591	25	635	19	483	221	91	
66	53	44.1	1120	220	99.5	80	2032	29.5	749	26	660	20	508	262	108	
72	57	50.6	1285	220	99.5	80	2032	29.5	749	26	660	20	508	262	108	
90	74	50.6	1285	250	113.1	101	2565	36	914	33	838	27	686	337	139	
96	76	50.6	1285	265	120	101	2565	36	914	37	940	31	787	348	144	
108	84	57.1	1450	280	126.7	122	3099	42.5	1080	39	991	33	838	404	166	
108	88	57.1	1450	285	129	122	3099	42.5	1080	39	991	33	838	404	166	
120	98	57.1	1450	290	131	122	3099	42.5	1080	42	1067	36	914	448	190	
132	106	76.6	1946	395	179	140	3556	52.75	1340	44	1118	38	965	486	205	
144	115	82.6	2098	425	192	160	4064	59	1499	51	1295	46	1168	524	223	
168	131	89.1	2263	465	210	181	4597	65.5	1664	59	1499	54	1372	598	253	
172	140	89.1	2263	475	214.9	181	4597	65.5	1664	78	1981	59	1499	637	271	
180	144	89.1	2263	480	217.2	181	4597	65.5	1664	83	2108	64	1626	658	278	
192	152	96.1	2441	515	233.0	202	5131	60	1524	83	2108	67	1702	693	296	
228	180	108.6	2758	590	267	244	6198	71	1803	92	2337	73	1854	821	348	
240	194	108.6	2758	595	269.2	244	6198	71	1803	103	2617	85	2169	885	375	
258	209	128.1	3254	700	316.7	262	6655	78.25	1988	111	2819	92	2337	952	424	
264	212	133.6	3393	725	328.1	282	7163	84.5	2146	116	2946	96	2438	966	429	
276	220	133.6	3393	730	330.3	282	7163	84.5	2146	120	3048	100	2540	1001	447	
288	234	140.6	3571	775	350.7	303	7696	91.5	2324	128	3252	106	2702	1069	474	
294	237	140.6	3571	786	355.7	303	7696	91.5	2324	130	3302	110	2794	1082	480	
300	243	140.6	3571	790	357.5	303	7696	91.5	2324	130	3302	110	2794	1100	492	
312	245	147.1	3736	800	362	324	8230	97.5	2477	130	3302	110	2794	1119	496	

### Porcelain Top Station Arrester

3	2.55	12	305	35	15.8	11.1	282	8.4	213	11	279	5.5	140	60	20	21
6	5.1	12	305	40	18.1	11.1	282	8.4	213	11	279	5.5	140	75	24	27
9	7.65	12	305	40	18.1	11.1	282	8.4	213	11	279	5.5	140	95	30	35
10	8.4	12	305	40	18.1	11.1	282	8.4	213	11	279	5.5	140	95	30	35
12	10.2	12	305	42	19.0	11.1	282	8.4	213	11	279	6.5	165	110	45	50
15	12.7	16.25	413	50	22.6	20	508	12.5	318	11	279	7.5	191	110	45	50
18	15.3	16.25	413	50	22.6	20	508	12.5	318	11	279	9	229	110	45	50
21	17	16.25	413	51	23.1	20	508	12.5	318	11	279	9	229	150	60	70
24	19.5	16.25	413	52	23.5	20	508	12.5	318	11	279	9	229	150	60	70
27	22	21	533	60	27	29	724	16.5	419	12	305	10	254	150	60	70

Note 1: These are recommended minimum clearances only and as such are not intended to take precedence over existing construction codes or specifications.

Note 2: 1 min. drying power withstand is not required by ANSI for 54 kv and above.

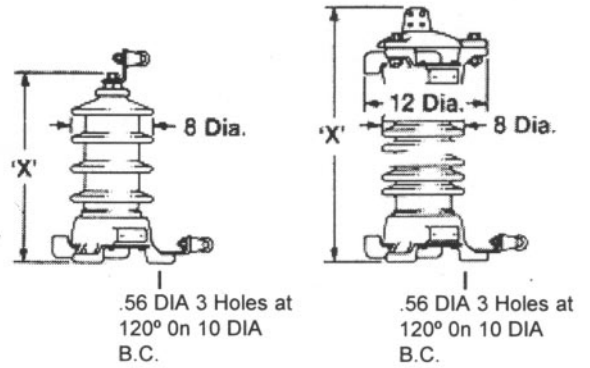

Fig. 2, 9L11ZGB0##S Series  
Rated Voltage 3-27kV

Fig. 3, 9L11ZGA0##S Series  
Rating Voltage 3-48kV

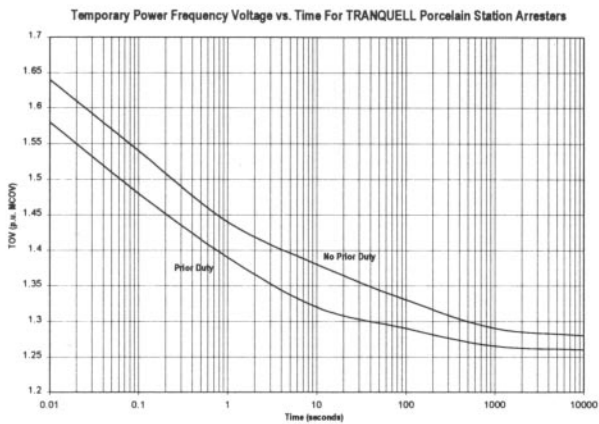
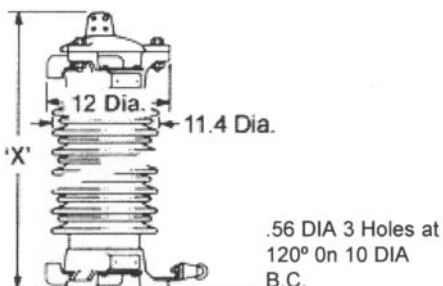

Fig. 1, Temporary Power Frequency Voltage vs. Time For TRANQUELL Porcelain Station Arresters  
(Prior Duty = 4.9kJ/kV of Rating for 3-48kV rating and 8.9kJ/kV for 54-312kV rating)





# Heavy Duty Distribution Arresters

## PROTECTIVE CHARACTERISTICS

Rated Voltage kV	MCOV kVrms	0.5 μsec 10 kA Max IR- kVcrest	Switching Surge Maximum IR- kV	8/20 Maximum Discharge Voltage (kV Crest)					
				1.5 kA	3 kA	5 kA	10 kA	20 kA	40 kA
3	2.6	12.5	8.0	9.5	10.0	10.5	11.0	13.0	15.3
6	5.1	25.0	16.0	19.0	20.0	21.0	22.0	26.0	30.5
9	7.7	34.0	22.5	24.5	26.0	27.5	30.0	35.0	41.0
10	8.4	36.5	23.5	26.0	28.0	29.5	32.0	37.5	43.5
12	10.2	43.5	28.8	30.7	32.9	34.8	38.5	43.8	51.5
15	12.7	54.2	35.0	38.4	41.0	43.4	48.0	54.6	64.2
18	15.3	65.0	42.1	46.0	49.1	52.0	57.5	65.4	76.9
21	17.0	69.5	44.9	49.5	52.5	55.7	61.5	69.9	82.2
24	19.5	87.0	56.4	61.6	65.8	69.6	77.0	87.6	103.0
27	22.0	97.7	63.2	69.2	73.9	78.2	86.5	98.4	115.7
30	24.4	108.4	71.0	76.8	82.0	86.8	96.0	109.2	128.4
36	29.0	130.0	84.2	92.0	98.2	104.0	115.0	130.8	153.8

## INSULATION CHARACTERISTICS

Rated Voltage (kV)	Creep in [mm]	Strike in [mm]	Minimum 1.2 x 50 μs Withstand (kV Crest)	Minimum Power Frequency (kV rms)	
				Wet (10sec)	Dry (1sec)
3	8 [203.2]	3.6 [91.4]	50	35	25
6	15.4 [391.2]	6.7 [170.2]	75	45	35
9	15.4 [391.2]	6.7 [170.2]	75	45	35
10	15.4 [391.2]	6.7 [170.2]	75	45	35
12	26 [660.4]	9.7 [246.4]	125	65	45
15	26 [660.4]	9.7 [246.4]	125	65	45
18	26 [660.4]	9.7 [246.4]	125	65	45
21	26 [660.4]	9.7 [246.4]	125	65	45
24	52 [1320.8]	18.0 [457.2]	160	90	65
27	52 [1320.8]	18.0 [457.2]	160	90	65
30	52 [1320.8]	18.0 [457.2]	160	90	65
36	52 [1320.8]	18.0 [457.2]	160	90	65

## DIMENSIONS, LEAKAGE DISTANCES, MOUNTING CLEARANCES & WEIGHTS

Mounting Clearance (1)					
MCOV	"X" Overall Height	Leakage Distance Terminal to Base	Center Line to Center Line	Center Line to Ground	Weight
kV	in [mm]	in [mm]	in [mm]	in [mm]	lb [kg]
2.55	7.0 [177.8]	8.0 [203.2]	5.0 [127]	3.0 [76.2]	3.2 [1.45]
5.10	9.3 [236.2]	15.4 [391.2]	5.4 [137.2]	3.4 [86.4]	4.0 [1.81]
7.65	9.3 [236.2]	15.4 [391.2]	6.0 [152.4]	4.0 [101.6]	4.0 [1.81]
8.40	9.3 [236.2]	15.4 [391.2]	6.2 [157.5]	4.2 [106.7]	4.0 [1.81]
10.2	12.3 [312.4]	26.6 [675.6]	7.5 [190.5]	5.5 [139.7]	5.4 [2.44]
12.7	12.3 [312.4]	26.6 [675.6]	8.5 [215.9]	6.5 [165.1]	5.4 [2.44]
15.3	12.3 [312.4]	26.6 [675.6]	9.5 [244.3]	7.5 [190.5]	6.0 [2.71]
17.0	12.3 [312.4]	26.6 [675.6]	10.0 [254.0]	8.0 [203.2]	6.0 [2.71]
19.5	21.0 [533.4]	52.0 [1320.8]	12.0 [304.8]	10.0 [254.0]	9.5 [4.30]
22.0	21.0 [533.4]	52.0 [1320.8]	13.0 [330.2]	11.0 [279.4]	9.5 [4.30]
24.4	21.0 [533.4]	52.0 [1320.8]	14.0 [355.6]	12.0 [304.8]	9.5 [4.30]
29.0	21.0 [533.4]	52.0 [1320.8]	16.5 [419.1]	14.5 [368.3]	10.7 [4.84]



Figure 14. TRANQUELL Heavy-Duty Distribution Arrester

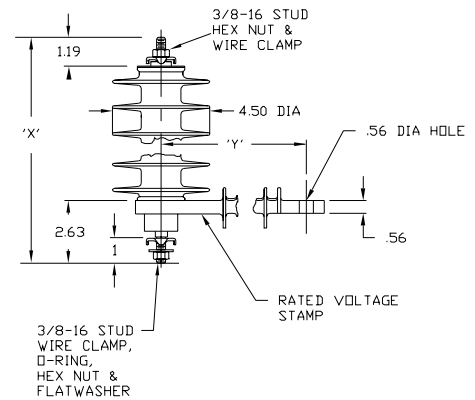

Y = 4 in. [101.6mm] for 3-10kV  
6 in. [152.4mm] for 12-36kV

Figure 15. TRANQUELL Heavy-Duty Distribution Arrester Dimensions



# GE Surge Arresters

## Riser Pole Arresters

### PROTECTIVE CHARACTERISTICS

Rated Voltage kV	MCOV kVrms	0.5 μsec 10 kA Max IR- kVcrest	500A Switching Surge Maximum IR- kVcrest	8/20 Maximum Discharge Voltage (kV Crest)					
				1.5 kA	3 kA	5 kA	10 kA	20 kA	40 kA
3	2.6	8.7	5.8	6.5	7.0	7.4	8.1	9.0	10.6
6	5.1	17.4	11.7	13.0	14.0	14.7	16.2	18.1	21.1
9	7.7	25.7	17.5	19.3	21.0	21.9	24.0	27.0	31.6
10	8.4	28.5	19.2	21.2	23.0	24.0	26.5	29.8	34.8
12	10.2	34.8	23.3	25.9	28.0	29.4	32.3	36.2	42.2
15	12.7	43.1	29.1	32.3	35.0	36.6	40.2	45.1	53.7
18	15.3	51.4	34.9	38.6	41.9	43.8	48.0	54.0	63.2
21	17.0	57.6	38.7	42.8	46.4	48.6	53.6	60.2	70.5
24	19.5	68.8	46.6	51.6	55.9	58.5	64.2	72.1	84.3
27	22.0	77.1	52.4	57.9	62.9	65.7	72.0	81.0	94.8
30	24.4	85.5	57.6	63.5	69.0	72.0	79.5	89.4	104.4
36	29.0	102.8	69.8	77.2	83.8	87.6	96.0	108.0	126.6



### INSULATION CHARACTERISTICS

Rated Voltage (kV)	Creep in [mm]	Strike in [mm]	Minimum 1.2 x 50 μs Withstand (kV Crest)	Minimum Power Frequency (kV rms)	
				Wet (10sec)	Dry (1sec)
3	15.4 [391.2]	4.9 [124.5]	75	45	35
6	15.4 [391.2]	4.9 [124.5]	75	45	35
9	15.4 [391.2]	4.9 [124.5]	75	45	35
10	15.4 [391.2]	4.9 [124.5]	75	45	35
12	30.8 [782.3]	6.5 [165.1]	130	70	50
15	30.8 [782.3]	6.5 [165.1]	130	70	50
18	30.8 [782.3]	6.5 [165.1]	130	70	50
21	30.8 [782.3]	6.5 [165.1]	130	70	50
24	46.2 [1173.5]	10.0 [254.0]	180	100	80
27	46.2 [1173.5]	10.0 [254.0]	180	100	80
30	46.2 [1173.5]	10.0 [254.0]	180	100	80
36	61.6 [1564.6]	14.0 [355.6]	220	130	100

Figure 16. TRANQUELL Riser Pole Arresters

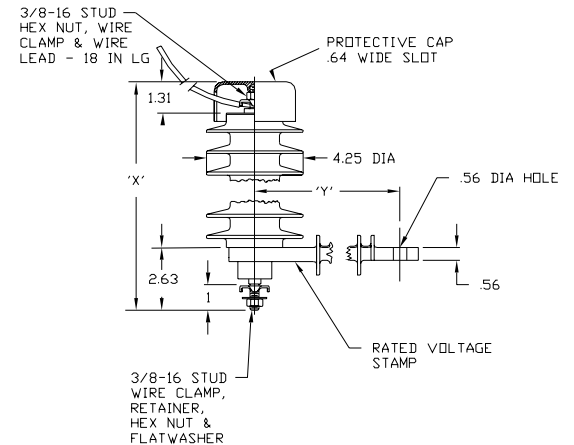

### DIMENSIONS, LEAKAGE DISTANCES, MOUNTING CLEARANCES & WEIGHTS

MCOV	"X" Overall Height	Mounting Clearance (1)			Weight
		Leakage Distance Terminal to Base	Center Line to Center Line	Center Line to Ground	
kV	in [mm]	in [mm]	in [mm]	in [mm]	lb [kg]
2.55	9.3 [236.2]	15.4 [391.2]	5.0 [127.0]	3.0 [76.2]	4.7 [2.12]
5.10	9.3 [236.2]	15.4 [391.2]	5.4 [137.2]	3.4 [86.4]	4.7 [2.12]
7.65	9.3 [236.2]	15.4 [391.2]	6.0 [152.4]	4.0 [101.6]	4.7 [2.12]
8.40	9.3 [236.2]	15.4 [391.2]	6.3 [160.0]	4.3 [109.2]	4.7 [2.12]
10.2	14.7 [373.4]	30.8 [782.3]	7.9 [200.7]	5.9 [149.9]	8.5 [3.83]
12.7	14.7 [373.4]	30.8 [782.3]	8.9 [226.1]	6.9 [175.3]	8.5 [3.83]
15.3	14.7 [373.4]	30.8 [782.3]	9.9 [251.5]	7.9 [200.7]	8.5 [3.83]
17.0	14.7 [373.4]	30.8 [782.3]	10.4 [264.2]	8.4 [213.4]	8.5 [3.83]
19.5	20.1 [510.5]	46.2 [1173.5]	12.4 [315.0]	10.4 [264.2]	12.0 [5.43]
22.0	20.1 [510.5]	46.2 [1173.5]	13.4 [340.2]	11.4 [289.6]	12.0 [5.43]
24.4	20.1 [510.5]	46.2 [1173.5]	14.0 [355.6]	12.0 [304.8]	12.0 [5.43]
29.0	25.4 [645.2]	61.6 [1564.6]	17.0 [431.8]	15.0 [381.0]	15.5 [6.98]

Y = 4 in. [101.6mm] for 3-10kV  
6 in. [152.4mm] for 12-36kV

Figure 17. TRANQUELL Riser Pole Dimensions



# Normal Duty Distribution Arresters

## PROTECTIVE CHARACTERISTICS

Rated Voltage kV	MCOV kVrms	0.5 μsec 10 kA Max IR- kVcrest	500A Switching Surge Maximum IR- kVcrest	8/20 Maximum Discharge Voltage (kV Crest)					
				1.5 kA	3 kA	5 kA	10 kA	20 kA	40 kA
3	2.6	12.5	8.5	9.8	10.3	11.0	12.3	14.3	18.5
6	5.1	25.0	17.0	19.5	20.5	22.0	24.5	28.5	37.0
9	7.7	33.5	23.0	26.0	28.0	30.0	33.0	39.0	50.5
10	8.4	36.0	24.0	27.0	29.5	31.5	36.0	41.5	53.0
12	10.2	50.0	34.0	39.0	41.0	44.0	49.0	57.0	74.0
15	12.7	58.5	40.0	45.5	48.5	52.0	57.5	67.5	87.5
18	15.3	67.0	46.0	52.0	56.0	60.0	66.0	78.0	101.0
21	17.0	73.0	49.0	55.0	60.0	64.0	73.0	84.0	107.0
24	19.5	92.0	63.0	71.5	76.5	82.0	90.5	106.5	138.0
27	22.0	100.5	69.0	78.0	84.0	89.0	99.0	117.0	151.5
30	24.4	102.8	72.0	81.0	88.5	94.5	108.0	124.5	159.0
36	29.0	134.0	92.0	104.0	112.0	120.0	132.0	156.0	202.0

## INSULATION CHARACTERISTICS

Rated Voltage (kV)	Creep in [mm]	Strike in [mm]	Minimum 1.2 x 50 μs Withstand (kV Crest)	Minimum Power Frequency (kV rms)	
				Wet (10sec)	Dry (1sec)
3	15.4 [391.2]	5.2 [132]	45	13	15
6	15.4 [391.2]	5.2 [132]	60	20	21
9	15.4 [391.2]	5.2 [132]	75	24	27
10	15.4 [391.2]	5.2 [132]	75	24	27
12	30.8 [782.3]	6.8 [172]	85	27	31
15	30.8 [782.3]	6.8 [172]	95	30	35
18	30.8 [782.3]	6.8 [172]	125	36	42
21	30.8 [782.3]	6.8 [172]	125	36	42
24	46.2 [1173.5]	10.3 [261]	150	60	70
27	46.2 [1173.5]	10.3 [261]	150	60	70
30	46.2 [1173.5]	10.3 [261]	150	60	70
36	61.6 [1564.6]	14.3 [363]	-	-	-

## DIMENSIONS, LEAKAGE DISTANCES, MOUNTING CLEARANCES & WEIGHTS

MCOV	"X" Overall Height	Mounting Clearance (1)			Weight
		Leakage Distance Terminal to Base	Center Line to Center Line	Center Line to Ground	
kV	in [mm]	in [mm]	in [mm]	in [mm]	lb [kg]
2.55	9.3 [236.2]	15.4 [391.2]	4.8 [121.9]	3.0 [76.2]	3.5 [1.58]
5.10	9.3 [236.2]	15.4 [391.2]	5.0 [127.0]	3.2 [81.3]	3.5 [1.58]
7.65	9.3 [236.2]	15.4 [391.2]	5.6 [142.2]	3.8 [96.5]	3.5 [1.58]
8.40	9.3 [236.2]	15.4 [391.2]	5.8 [147.3]	4.1 [104.1]	3.5 [1.58]
10.2	14.7 [373.4]	30.8 [782.3]	7.5 [190.5]	5.7 [144.8]	6.7 [3.03]
12.7	14.7 [373.4]	30.8 [782.3]	8.5 [215.9]	6.7 [170.2]	6.7 [3.03]
15.3	14.7 [373.4]	30.8 [782.3]	9.5 [241.3]	7.7 [195.6]	6.7 [3.03]
17.0	14.7 [373.4]	30.8 [782.3]	10.0 [254.0]	8.2 [208.3]	6.7 [3.03]
19.5	20.1 [510.5]	46.2 [1173.5]	12.0 [304.8]	10.2 [259.1]	10.0 [4.52]
22.0	20.1 [510.5]	46.2 [1173.5]	13.0 [330.2]	11.2 [284.5]	10.0 [4.52]
24.4	20.1 [510.5]	46.2 [1173.5]	13.6 [345.4]	11.8 [299.8]	10.0 [4.52]
29.0	25.4 [645.2]	61.6 [1564.6]	16.2 [411.5]	14.4 [365.8]	13.3 [6.02]



Figure 18. TRANQUELL Normal-Duty Arrester

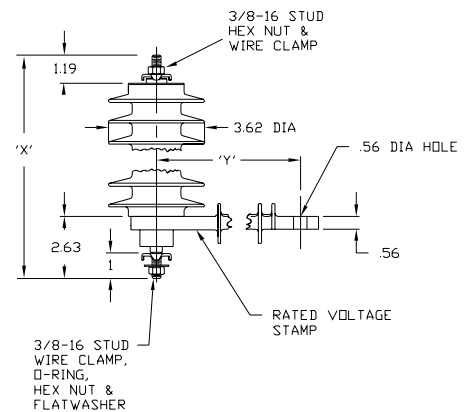

Y = 4 in. [101.6mm] for 3-10kV  
6 in. [152.4mm] for 12-36kV

Figure 19. TRANQUELL Normal-Duty Arrester Dimensions



# Special Applications of TRANQUELL Metal Oxide Technology

In some power system installations, special TRANQUELL® arresters are required to address the particular needs of the application. These requirements include high energy capability, low protective levels, or unusual voltage stresses such as harmonic or dc voltages. GE has applied the unique capabilities of metal oxide disks in many situations including series capacitors, HVDC converter stations, and transmission lines.

### SERIES CAPACITOR PROTECTION

A multiple column varistor consisting of metal oxide disks placed directly in parallel with a series capacitor can protect it against overvoltages resulting from faults on the system. In the GE series capacitor protective system, the varistor diverts the line fault current around the capacitor for a predetermined number of cycles after which time a bypass switch or triggered gap will operate to limit the energy dissipation. For most faults, only the varistor will conduct and the capacitors are reinserted immediately following the fault greatly promoting power system stability by maintaining continuous power flow.

### HVDC TERMINALS

HVDC back-to-back, separated, and multiterminal converter stations provide a unique opportunity for the application of TRANQUELL surge arresters. Stable protective characteristics and multiple column arrester designs simplify the insulation coordination process on both the AC and DC systems.

In many cases, equipment insulation can be reduced resulting in a reduction in size and cost of the terminal. TRANQUELL AC and DC surge arresters can be applied to systems where a wide variety of steady-state voltage wave-shapes are encountered. For example, bridge arresters are exposed to DC voltages with periodic polarity reversals while AC filter reactor arresters are exposed to power frequency and harmonic voltages. GE has supplied the arresters for many HVDC converter stations worldwide.

### HIGH ENERGY CIRCUITS

Individual series stacks of metal oxide disks are carefully matched by GE to

achieve ideal energy sharing when many of these stacks are conducting in parallel. More than one column of metal oxide disks may be placed in one porcelain housing. This provides a number of opportunities for special arresters in circuits requiring compact extra high energy dissipation capability.

Special arresters and multiple parallel stack metal oxide varistors have applications in various areas inside and outside the power industry. A list of such applications follows:

- Shunt reactor neutral
- HVDC breaker and current limiting device
- Subsynchronous resonance filters
- Static VAR systems
- High power laboratory test circuits
- Fusion reactor coils
- Transformer overexcitation
- Voltage limitation during load rejection
- Motor and generator protection during transformer through faults
- Internal transformer windings

## References

- [1] Application Guide - TRANQUELL Station Surge Arresters, GET-6460.
- [2] ANSI/IEEE C62. 11-1993 - Standard for Metal Oxide Surge Arresters for Alternating Current Power Circuits.
- [3] International Electrotechnical Commission, IEC 99-4(1991), "Part 4: Metal Oxide Surge Arresters Without Gaps for A.C. Systems".
- [4] ANSI/IEEE C62.1 - 1989, Standard for Gapped Silicon-Carbide Surge Arresters for AC Power Circuits.
- [5] ANSI/IEEE C62.2-19xx, Guide for the Application of Metal Oxide Surge Arresters for AC Systems.
- [6] Electric Power Research Institute, "Transmission Line Reference Book, 345 kV and Above/Second Edition," 1982.
- [7] ANSI C2-1984, National Electrical Safety Code.
- [8] ANSI C29.9-1983, - American National Standard for Wet-process Porcelain Insulators - Apparatus, Post-type.
- [9] ANSI C57.12.00-1980, General Requirements for Liquid-immersed Distribution, Power, and Regulating Transformers.
- [10] IEEE Working Group of the Lightning Protective Devices Sub-committee, Lightning Protection in Multi-line Stations, IEEE Transactions, June 1968, pp 1514-1521.
- [11] AIEE Working Group of the Lightning Protective Devices Sub-committee, Simplified Method for Determining Permissible Separation Between Arresters and Transformers, AIEE Transactions, Special Supplement, pp. 33-57, 1963.
- [12] E.C. Sakshaug, J.S. Kresge, and S.A. Miske, Jr., "A New Concept in Station Arrester Design," IEEE Transactions on Power Apparatus and Systems, Vol. PAS-96, No. 2, March/April 1977.

For more info.....

*GE Capacitor and Power Quality Products*

*381 Broadway*

*Ft. Edward, NY 12828-1000*

*[www.geindustrial.com/industrialsystems/products/capacitors.shtml](http://www.geindustrial.com/industrialsystems/products/capacitors.shtml)*



---

**GE Arresters**

**FETA-100a (8/99)**